



Wall-Mount Bracket

安全のために	JP
Safety Information	EN
Consignes de sécurité	FR
Información de seguridad	ES
Sicherheitsinformationen	DE
Veiligheidsinformatie	NL
Informazioni di sicurezza	IT
Säkerhetsinformation	SE
Informacje dotyczące bezpieczeństwa	PL
Informações de segurança	PT
Sikkerhedsoplysninger	DK
Turvallisuusohjeet	FI
Sikkerhetsinformasjon	NO
Πληροφορίες σχετικά με την ασφάλεια	GR

Güvenlik Bilgileri	TR
Biztonsági előírások	HU
Bezpečnostní informace	CZ
Informácie o bezpečnosti	SK
Informații privind siguranța	RO
Информация за безопасност	BG
Сведения по безопасности	RU
Інформація щодо безпечної експлуатації	UA
Thông tin An toàn	VN
安全資訊	CT
安全信息	CS
ข้อมูลความปลอดภัย	TH
Informasi Keselamatan	ID

Wall-Mount Bracket

On Safety

Thank you for purchasing this product.

To Customers

Installing the TV or LCD Monitor to the Wall



PROFESSIONAL INSTALLATION REQUIRED

This product should only be installed by a professional installer who is trained to determine the strength of the wall for withstanding the TV's or LCD Monitor's weight. If it is not properly secured during installation, the TV or LCD Monitor may fall and cause serious injury. Sony is not liable for any damage or injury caused by mishandling or improper installation, or installing any other than the installable product. Your Statutory Rights (if any) are not affected.

To Sony dealers

Sufficient expertise is required for installing this product. Be sure to read this instruction manual thoroughly to do the installation work safely. Sony is not liable for any damages or injury caused by mishandling or improper installation. Please give this manual to the customer after installation.

This instruction manual shows the correct handling of the product and important precautions necessary to prevent accidents. It is your responsibility to read, thoroughly understand, and follow all instructions in this instruction manual. Failure to do so may result in serious personal injury or property damage, and may void the warranty. Keep this manual available for future reference.

Products by Sony are designed with safety in mind. If the products are used incorrectly, however, it may result in a serious injury through fire, electric shock, the product toppling over, or the product dropping. Be sure to observe the precautions for safety to prevent such accidents.

To Customers

WARNING

If the following precautions are not observed, serious injury or death through fire, electric shock, or the product dropping can result.

Be sure to subcontract the installation to licensed contractors and keep small children away during the installation.

If the Wall-Mount Bracket or the TV or LCD Monitor is not installed correctly, the following accidents may occur. Be sure licensed contractors carry out installation.

- The TV or LCD Monitor may fall and cause a serious injury such as a bruise or a fracture.
- If the wall on which the Wall-Mount Bracket is installed is unstable, uneven, or not perpendicular to the floor, the unit may fall and cause injury or property damage. The wall should be capable of supporting a weight of at least four times the TV or LCD Monitor weight. (Refer to your TV's or LCD Monitor's Reference Guide for its weight.)
- If the installation of the Wall-Mount Bracket on the wall is not sufficiently sturdy, the unit may fall and cause injury or property damage.

Be sure to subcontract moving or dismantling of the TV or LCD Monitor to licensed contractors.

If persons other than licensed contractors transport or dismount the TV or LCD Monitor, it may fall and cause injury or property damage. Two or more persons (three or more persons for 189.3 cm (75 inches) and above TV or LCD Monitor) are needed to transport a large TV or LCD Monitor (except Egypt).

Two or more persons (three or more persons for 75 inches (189.3 cm) and above TV or LCD Monitor) are needed to transport a large TV or LCD Monitor (Egypt only).

Do not remove screws, etc., after mounting the TV or LCD Monitor.

If you do so, the TV or LCD Monitor may fall and cause injury or property damage.

Do not make alterations to the parts of the Wall-Mount Bracket.

If you do so, the Wall-Mount Bracket may fall and cause injury or property damage.

Do not mount any equipment other than the installable product.

This Wall-Mount Bracket is designed for use with the installable product only. If you mount equipment other than specified, it may fall or break, and cause injury or property damage.

Do not apply any load other than the TV or LCD Monitor on the Wall-Mount Bracket.

Do not shake the TV or LCD Monitor left/right, up/down.

If you do so, the TV or LCD Monitor may fall and cause injury or property damage.

Do not lean on or hang from the TV or LCD Monitor.

Do not lean on or hang from the TV or LCD Monitor as it may fall on you and cause serious injury.

ALWAYS keep small accessories out of the reach of children, so that they are not mistakenly swallowed.

CAUTION

If the following precautions are not observed, injury or property damage may occur.

- Be careful to not pinch your fingers while handling the Wall-Mount Bracket or swiveling the TV or LCD Monitor.
- While swiveling the TV or LCD Monitor, handle it with caution and take care not to hit any people nearby.
- Be sure to store the unused parts in a safe place for future use. Keep them away from children.

Do not handle the product with excessive force during cleaning or maintenance.

Do not apply excessive force on the topside of the TV or LCD Monitor. If you do so, the TV or LCD Monitor may fall and cause injury or property damage.

Do not place this product close to medical devices.

This product (including accessories) has magnet(s) which may interfere with pacemakers, programmable shunt valves for hydrocephalus treatment, or other medical devices. Do not place this product close to persons who use such medical devices. Consult your doctor before using this product if you use any such medical device.

Keep out of the reach of children or the supervised individuals.

This product (including accessories) has magnet(s). Swallowing magnet(s) could cause serious harm, such as choking hazard or intestinal injuries. If magnets (or a magnet) were swallowed, consult a doctor immediately.

Precautions

- If you use the TV or LCD Monitor installed on the Wall-Mount Bracket for a long time, the wall behind or above the TV or LCD Monitor may become discolored or the wallpaper may come unstuck, depending on the material of the wall.
- If the Wall-Mount Bracket is removed after installing it on the wall, the screw holes are left.
- Do not use the Wall-Mount Bracket in a place where it is subjected to mechanical vibrations.

Installing the Wall-Mount Bracket

To Sony Dealers

WARNING

The following instructions are for Sony dealers only. Be sure to read safety precautions described above and pay special attention to safety during the installation, maintenance and checking of this product.

Do not install the Wall-Mount Bracket on wall surfaces where the corners or the sides of the TV or LCD Monitor protrude away from the wall surface.

Do not install the Wall-Mount Bracket on wall surfaces such as a pillar, where the corners or the sides of the TV or LCD Monitor protrude away from the wall surface. If a person or object happens to hit the protruded corner or side of the TV or LCD Monitor, it may cause injury or property damage.

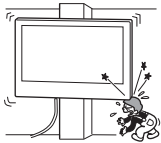

Do not install the TV or LCD Monitor over or under an air-conditioner.

If the TV or LCD Monitor is exposed to water leaks or air current from an air conditioner for a long time, it may cause a fire, an electric shock or a malfunction of the TV or LCD Monitor.

Be sure to install the Wall-Mount Bracket securely to the wall following the instructions in this instruction manual.

If any of the screws are loose or fall out, the Wall-Mount Bracket may fall and cause injury or property damage. Be sure to use the appropriate screws for the material of the wall and install the unit securely using six or more screws of 8 mm diameter (or equivalent).

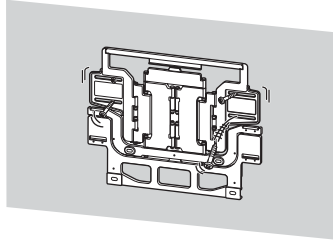

Be sure to use the supplied screws and attachment parts properly following the instructions given in this instruction manual. If you use substitute items, the TV or LCD Monitor may fall and cause bodily injury to someone or damage to the TV or LCD Monitor.

Be sure to assemble the bracket properly following the instructed procedure explained in this instruction manual.

If any of the screws are loose or fall out, the TV or LCD Monitor may fall and cause bodily injury to someone or damage to the TV or LCD Monitor.

Be sure to tighten the screws securely in the designated position.

If you fail to do so, the TV or LCD Monitor may fall and cause bodily injury to someone or damage to the TV or LCD Monitor.

Be careful not to subject the TV or LCD Monitor to shock during installation.

If the TV or LCD Monitor is exposed to shock, it may fall or break apart. This may cause injury.

Be sure to install the TV or LCD Monitor on a wall that is both perpendicular and flat.

If you fail to do so, the TV or LCD Monitor may fall and cause injury.

After proper installation of the TV or LCD Monitor, secure the cables properly.

If people or objects get tangled with cables, this may result in injury or damage to the TV or LCD Monitor.

Do not allow the AC power cord or the connecting cable to be pinched.

If the AC power cord or the connecting cable is pinched between the unit and the wall or is bent or twisted by force, the internal conductors may become exposed and cause a short circuit or an electrical break. This may cause a fire or an electric shock.



The screws needed to secure the Wall-Mount Bracket to the wall are not supplied.

Use the appropriate screws for the wall material and structure when mounting the Wall-Mount Bracket.

For customers in Europe

For instruction on installing the Wall-Mount Bracket to your TV or LCD Monitor please download the information at SONY website.

This product has been manufactured by or on behalf of Sony Corporation.

EU and UK Importer: Sony Europe B.V.

Inquiries to the EU Importer or related to product compliance in Europe should be sent to the manufacturer's authorized representative, Sony Belgium, bijkantoor van Sony Europe B.V., Da Vincilaan 7-D1, 1930 Zaventem, Belgium.

Inquiries to the UK Importer or related to product compliance in the UK should be sent to the manufacturer's authorized representative, Sony Europe B.V., The Heights, Brooklands, Weybridge, Surrey KT13 0XW, United Kingdom.

Before installing the TV or LCD Monitor to the Wall

Your TV or LCD Monitor can be mounted to a wall using this Wall-Mount Bracket. If the Table-Top Stand is not attached to the TV or LCD Monitor, the TV or LCD Monitor may require attaching the Table-Top Stand first. See TV's or LCD Monitor's Setup Guide.

Prepare the TV or LCD Monitor for the Wall-Mount Bracket before making cable connections.

Wall-Mount Bracket Installation Instruction

The instructions for installing the TV or LCD Monitor on a wall using a **Sony Wall-Mount Bracket** can be found on the TV's or LCD Monitor's model page.

<https://www.sony.net/SonyInfo/Support>

For product protection and safety reasons, Sony strongly recommends that installation of your TV or LCD Monitor on the wall be performed by qualified professionals. Do not attempt to install it yourself.

Preparing for Wall-Mount Installation

- Sufficient expertise is required in installing the TV or LCD Monitor, especially to determine the strength of the wall for withstanding the TV's or LCD Monitor's weight.
- Refer to the following table for wall-mount hole pattern.

Wall-mount hole pattern
$a \times b$
300 × 300 mm
400 × 400 mm

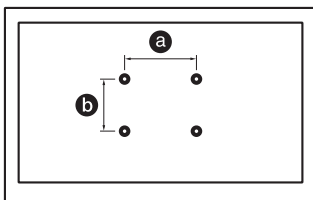

- Be sure to store the unused screws and Table-Top Stand in a safe place until you are ready to attach the Table-Top Stand. Keep the screws away from small children.

Specifications

WM1

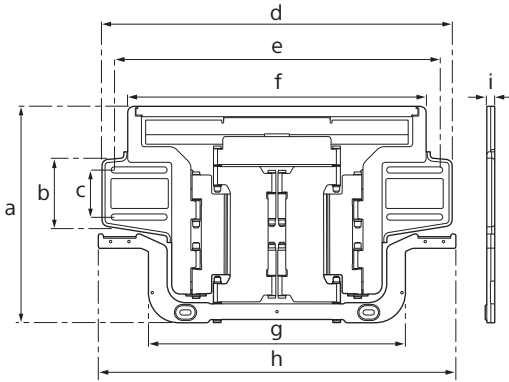

WM5

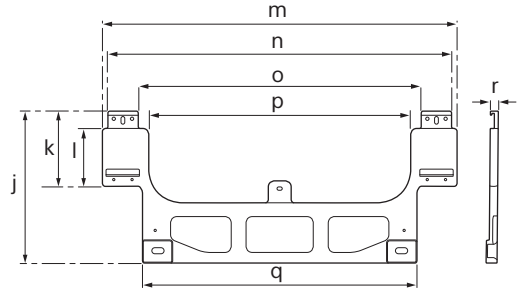

Dimensions: (Approx.) (mm)

a : 354.5	h : 585	o : 465.1
b : 107.5	i : 13	p : 430
c : 77	j : 249.5	q : 451
d : 573	k : 123.5	r : 13
e : 533	l : 95	
f : 488	m : 583	
g : 420	n : 565	

Mass (base only): (Approx.) (kg)

WM1 5.1

WM5 0.5

Design and specifications are subject to change without notice.

EN