

uControl™

uControl Remote

PRODUCT GUIDE

Contents.

In the box	2
Helpful things to know	3
Adding to your WiFi network	4-5
Configuring for use	6-7
Device diagram & details	8-9
Specifications	10-11
Adding to HDA Systems	12
Multiple Zones with multiple uControl Remotes using MHUB	13
Media or cinema rooms with MHUB	14
Media or cinema rooms with Zone or Connect Processors	15
Warranty information	16-17

In the box.

x1 uControl Remote (Plastic or Aluminium)

x1 25cm | 9.84 inches USB-C Charging Cable

x1 1200mAh Battery (Installed)

Helpful things to know.

Connect the uControl Remote to the Internet at least once before setup to initialise it.

If the installation network lacks Internet access, connect the uControl Remote to any available WiFi with Internet (see steps on page 4-5), then reconnect again at the installation site to carry out the full uControl Remote configuration (see steps on page 6-7). After setup and configuration, an Internet connection is not needed for normal operation.

Create MAC address reservations for your uControl Remote IP addresses.

uControl Remote does not support fixed IP addressing. It is recommended that you create MAC address reservations from the router instead to manage your uControl Remote.

Test that everything works from uControl App first.

Test commands, Sequences and Functions using the uControl App before starting the uControl Remote setup and configuration process.

Charge the uControl Remote after every use.

It is recommended that you charge the uControl Remote after every use for optimal performance.

Keep your customisation simple.

Avoid hiding too many controls as long press events or putting all room/Zone controls on to the uControl Remote. Remember: its primary purpose is to be a great remote for TV and music. Try to keep your customisations simple and easy to use.

Backup your configuration!

Backup your configuration on your uOS controller. This setting can be found in the advanced page within uOS.

Instant-On availability.

When the uControl Remote is charging, it will not enter deep sleep mode, ensuring it remains available for immediate control. However, if the remote detects no activity—such as movement from the accelerometer or key presses—for an extended period, it will enter deep sleep mode. Waking from deep sleep typically takes 5 to 10 seconds, depending on your WiFi network. You can adjust the deep sleep settings through the HDA Key menu (see pages 8-9).

The uControl Remote will update automatically if it is connected to the Internet.

The uControl Remote will update automatically if it is connected to a network that can reach the Internet. This is a separate process to updating your controller hardware which must be done manually.

Adding to your WiFi network.

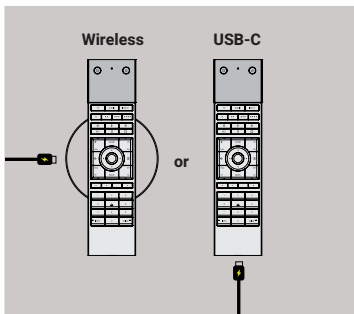

1

Charge the uControl Remote.

Ensure the uControl Remote is fully charged before setup. Place it on a charging pad or connect it to a power source using the provided USB-C cable.

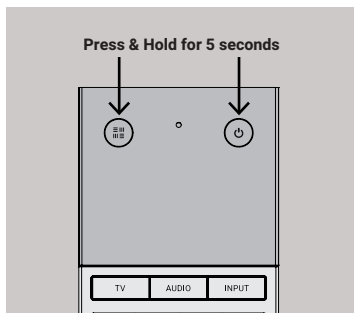

2

Power ON the uControl Remote.

Press and hold both the HDA and Power keys for 5 seconds until the device turns on. It will boot up and display "DISCOVERY MODE" showing its WiFi network name (SSID) and IP address.

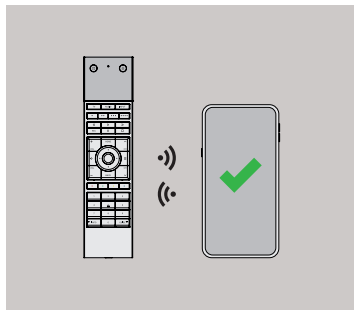

3

Connect to the uControl Remote's WiFi.

On a PC, tablet, or smartphone, go to your WiFi settings and connect to the uControl Remote's WiFi network.

Password: **hdanywhere**

4

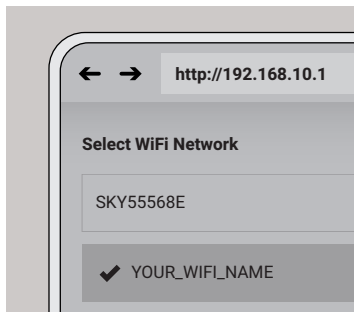

Access the uControl Remote's Network Page.

Open a browser and go to:
<http://192.168.10.1>

Follow the on-screen instructions to connect the uControl Remote to your local WiFi network.

5

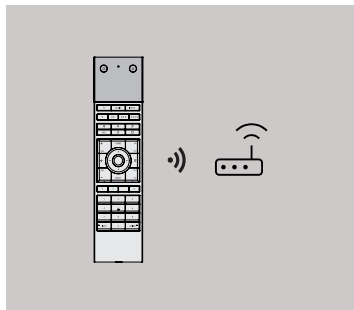

Wait for connection.

The uControl Remote will attempt to connect to your WiFi. The screen will update with its progress. If it fails, double-check your WiFi credentials and try again.

6



Note your new IP address.

Once the connection is successful, the uControl Remote will display a confirmation message along with its new IP address. Write this down—you'll need it later for configuring (see pages 6-7).

Configuring for use.

1

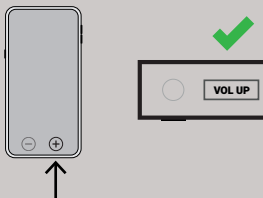

Test with the App first.

Before adding the uControl Remote to a Zone or Room, test all commands, Sequences and Functions for that Zone using the uControl App. This is faster than testing with the Remote, saving you time during setup.

2

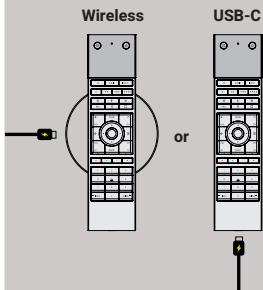

Charge the uControl Remote.

Ensure the uControl Remote is fully charged before setup. Place it on a charging pad or connect it to a power source using the provided USB-C cable.

3

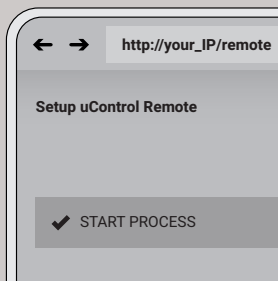

Start the setup process.

Access the IP address of your MHUB, uControl Zone, or Connect Processor to open the uOS interface. From the navigation menu, select the "Remotes" page to begin the setup process. Follow the on-screen instructions to complete the basic setup.

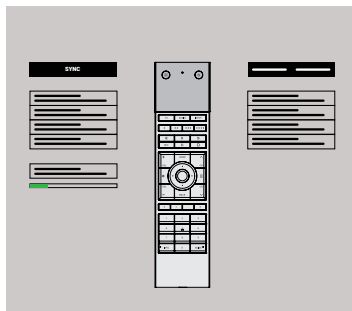

4

Add customisations.

After the basic setup, you'll enter the uControl Remote advanced setup. Here, you can further customise the uControl Remote to match your specific control preferences.



5

Transfer configuration to uControl Remote.

Tap the Sync button to send your customisations to the uControl Remote. Transfer should take less than 2 minutes after which the uControl Remote will reboot.

Important: Don't forget to sync your data to save changes. If you exit without syncing, any customisations made after the basic setup will be lost.



6

uControl Remote is ready to use.

After rebooting, the uControl Remote will display its home screen, showing the active Zone and input controls.

Your uControl Remote is now ready to use.

uControl Remote in detail.

- 1 Infrared (IR) window**
IR Transmit & Learn LED window.
- 2 HDA Key (System Keys)**
Reveals uControl Remote system settings for network information, reset, power and software versions.
- Power Key**
Supports short press and long press actions. Press this key to reveal a list of options to power ON devices in your Zone. Press and hold this key to reveal a list of options to power OFF devices in your Zone. If you have selected a Sequence to automate the ON or OFF actions from your controller then this will be presented at the top of each list.
- 4 Microphone**
Microphone input (for future use).
- 5 OLED Screen**
Displays active control options, the Zone the uControl Remote is assigned to, menus and feedback from the wider uControl system.
- 6 Input Selector Keys**
Select between "TV", "Audio" or "Input" to map uControl Remote's keys (#8) to another device for control. If multiple devices exist, a menu will appear.
- 7 Sequence Keys**
Assign uOS Sequence(s) or Functions to these keys to control AV, lighting, blinds, shades etc. These keys can be customised to support short press or long press actions or provide feedback via the OLED screen. This can be customised in uOS.
- 8 Mappable Keys**
Mapped keys from uControl Packs. All keys apart from Volume, Channel and Direction Pad can be customised with additional actions.
- 9 Directional Pad (D-Pad)**
Used to navigate menus triggered by the System Settings, Power, Input Selector, or Sequence keys. When no menu is active, the D-Pad defaults to controlling the current device. Once a menu is displayed, the D-Pad will control that menu until it is closed, after which it will return to device control, which is the default behaviour.
- 10 USB-C charging port**
Connect a USB-C cable to this port to charge the uControl Remote. Used only for power.
- 11 Charging Area**
Marked in green, this area is where the charging coil of the uControl Remote is located. Place this area directly above your charging pad to commence wireless charging.

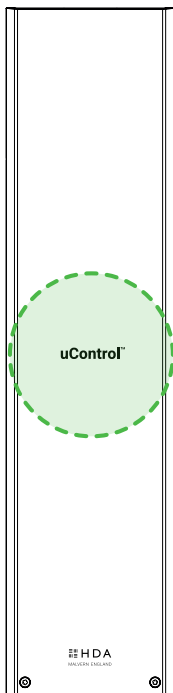
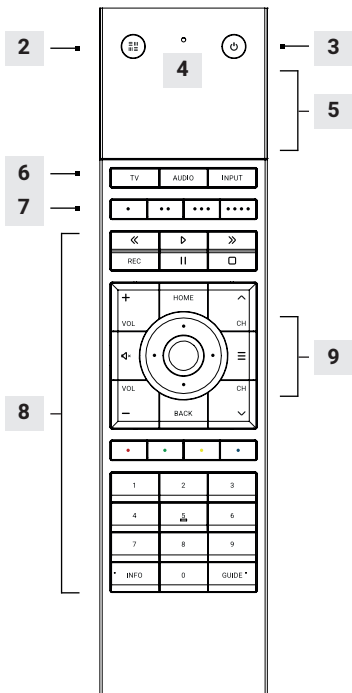
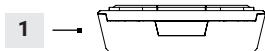

Specifications.

Dimensions (W/H/D)	50.38 x 207.05 x 12.13 mm 1.98 x 8.14 x 0.47 inches
Materials	ABS Plastic / ABS Plastic & Aluminium
Colour (Plastic)	Black
Colours (Aluminium)	Carbonite, Custom
Weight	124g 4.37 ounces
Package Weight	300g 10.58 ounces
Aerials	WiFi (2.4Gz) BT Low Energy (5.1)
WiFi type	802.11bgh (2.4)
IO & Sensors	Accelerometer, Microphone
IR Type(s)	Learn + Transmit
IR Frequency	36KHz/38KHz/56KHz
IR Spread	Range: (13m 42ft) Y Pitch: (+/- 30°) X Pitch: (+/- 20°)
Charging	USB-C or Wireless
Charge time	90 minutes (80% under 60 minutes)
Battery	1200mAh
Warranty	2 Years

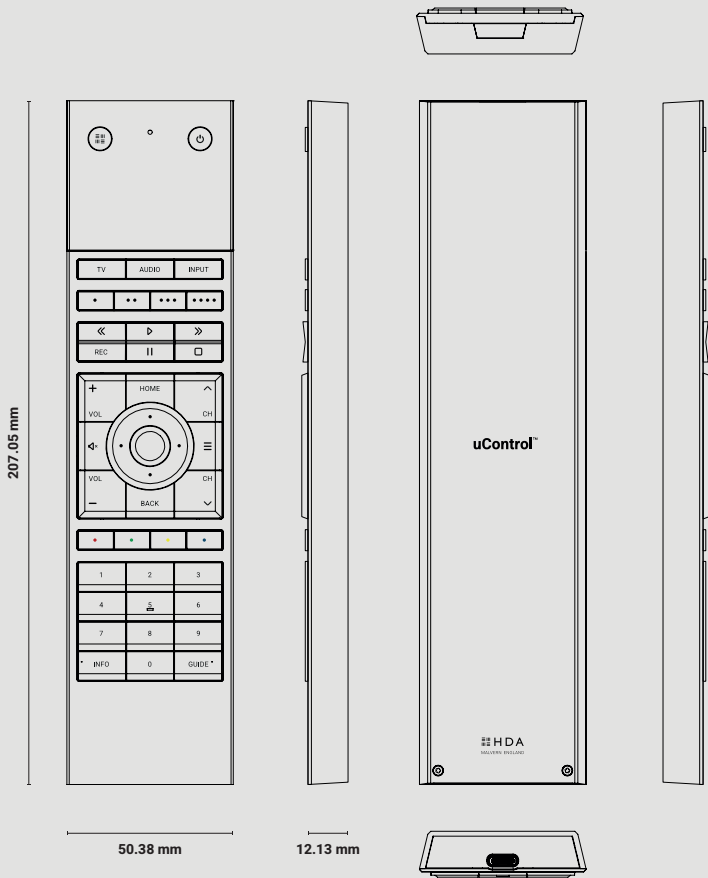

Adding to HDA Systems.

The following sections describe a common setup for using the uControl Remote with controllers like HDA's MHUB system, uControl Zone Processors, or uControl Connect Processors.

Since control projects can vary, these diagrams provide a basic framework for deploying the uControl Remote in typical scenarios.

For maximum control flexibility, use MHUB.

Adding the uControl Remote to MHUB gives you more options, like mobile IR transmission, IR control for all sources, and CEC-based automations (which are often better than IP control, especially for displays).

MHUB Mini is ideal for home cinemas and media rooms.

With two outputs and a HDMI mirror for the AVR, the MHUB Mini (4x1+1) 40 is perfect for single-room setups where more than one display is needed.

CEC control is only for displays.

uControl's CEC functionality is for displays only and cannot be used with AVRs or video sources.

IP control is recommended for better user experience and automation.

IP control has two main advantages over IR. First, when using MHUB, you can assign AVRs to a Zone, making it the primary volume controller that Zone. Secondly, IP control usually uses discrete commands, which can be added to custom actions on the uControl Remote. For example, when switching control from Sky to Apple TV, you can instruct the AVR to switch to the correct input.

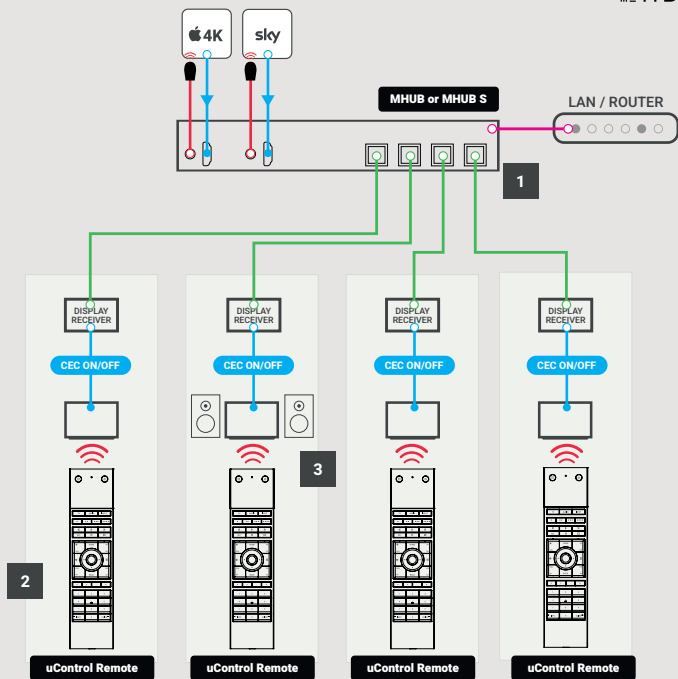

Multiple uControl Remotes in multiple Zones.

1

MHUB is the recommended hardware choice when using multiple uControl Remotes with multiple displays and/or Zones.

2

You have the choice to emit IR commands from the Remote or from the display receiver IR emitter. Additionally, you also gain the option to use CEC for on/off behaviours.

3

If a Zone contains an audio output from MHUB or MZMA or an AVR, then you can transfer volume control to the uControl Remote.

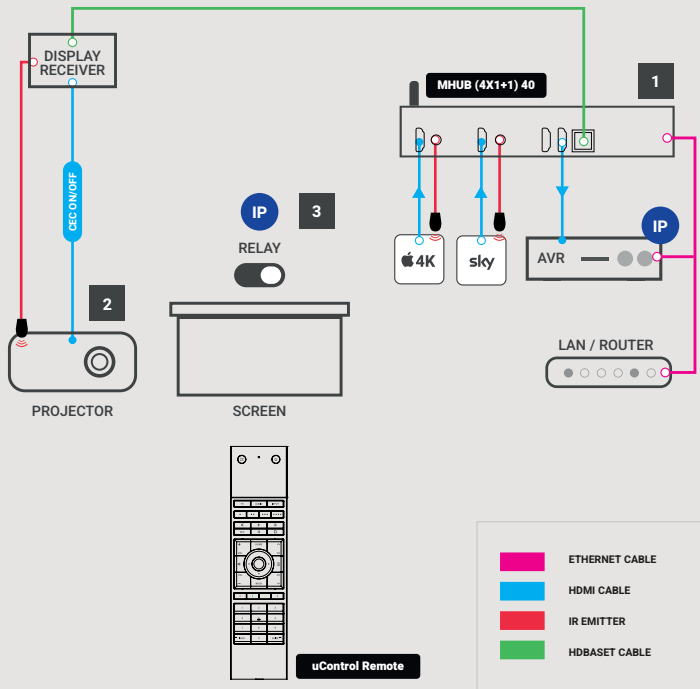

Media room or cinema with MHUB.

- 1 With superior EDID and multizone capabilities, it is recommended to install MHUB (4x1+1) 40 or "MHUB Mini" for cinema or media rooms.
- 2 Use the IR emitter connected to MHUB's display receiver to control devices where uControl Remote's on-board IR has no direct line-of-sight.
- 3 Creating a Function with a relay to allow Sequences for Room Off or Room ON to control the state of the relay, allowing for screens to be dropped or raised, as an example.

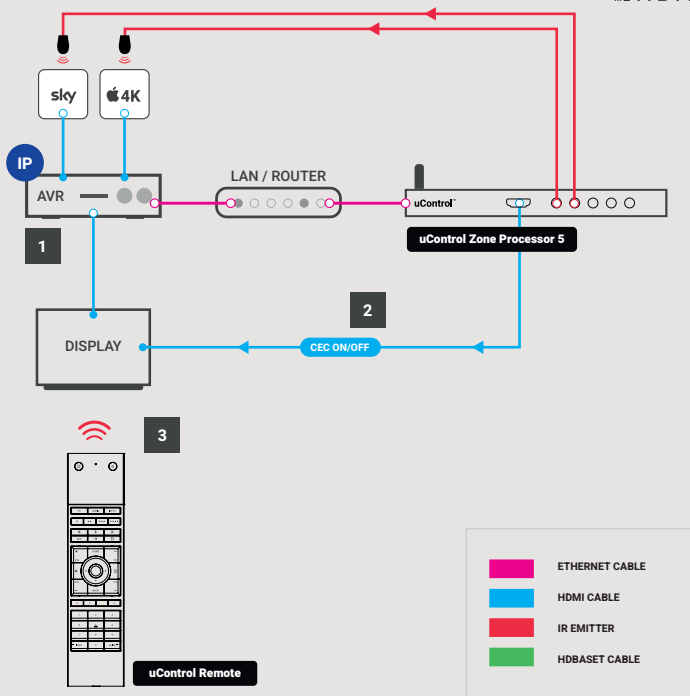

Cinema room using a uControl Zone Processor.

- 1 It is recommended to use an IP Pack (if supported) to control the AVR so that the uControl Remote can switch inputs on the AVR when an input control is selected.
- 2 Use the optional CEC port on the Zone Processor to automate Room OFF or Room ON operations on the display (if supported).
- 3 Choose to emit IR from the Zone Processor or the uControl Remote. Our recommendation is to transfer IR for the display to the Remote in this scenario.

2 Year Guarantee.

WHO WE ARE

1. We are HD CONNECTIVITY LTD trading as HDA (HDA), a limited company registered under number 06046737 in England and Wales with its registered offices at The Haysfield, Malvern, WR14 1GF, United Kingdom.

OUR GUARANTEE TO YOU

2. We, HDANYWHERE warrant to you, the end user of the HDA hardware (the "Products") that on the date of delivery of the Products to you, and for a period of 2 years from that date of delivery, the Products shall:

- match any description that has been provided to you;
- be free from any significant defects in their design, the materials used to make them, and the way they are made;
- be of satisfactory quality (within the meaning of the Consumer Rights Act 2015); and
- be fit for any purpose held out by us.

This 2 year period, or, if the period has been extended to 3 years in accordance with paragraph 3, will be the "Guarantee Period". We offer this guarantee to all our customers who are resident and have an address in Great Britain and Northern Ireland.

EXTENDING YOUR GUARANTEE (NOT APPLICABLE TO ANY XTND or UCONTROL PRODUCT)

3. On registering your Products with the HDA Cloud, the guarantee offered in paragraph 2 by us will automatically extend for a period of one year, provided that your registration takes place within 30 days from the date of delivery. The one year guarantee extension starts automatically from the date that the original 2 year guarantee ends.

HOW TO CLAIM ON YOUR GUARANTEE AND YOUR REMEDIES

4. Subject to paragraphs 5 and 6 of this guarantee, Your sole remedies under Our guarantee to You are as follows:

- Up to 30 days: we will repair or replace your Products or provide you with a full refund of the price of the defective Products at your option.
- Up to 6 Months: we will repair or replace your Products. If we are unable to repair or replace your Products we will provide you with a full refund of the price of the defective Products.
- Up to 2 (3) Years: we will repair or replace your Products. If we are unable to repair or replace your Products we will provide you with a partial refund of the price of the defective Products based upon the devaluation of the Products since the time of purchase.

5. In order to claim under the guarantee given to you in paragraph 2 you will need to:

- give us notice in writing of your intention to claim under the guarantee during the Guarantee Period, and do so within a reasonable time after finding that some or all of the Products do not comply with the guarantee set out in paragraph 2;
- show that the Products that you claim are defective, have been examined by a HDA Pro or other authorised or suitably qualified installer, and that they have [MG3] confirmed in writing that the suspected defect in the Products stems solely from a fault in the HDA hardware;
- give us a reasonable opportunity to examine the Products in question;
- provide us with an order number and a dated sales or delivery receipt from an HDA Distributor, HDA Pro or other authorised dealer, reseller or installer of the Products.
- obtain from us in advance of returning the Products a return merchandise authorisation and/or case number [MG4]; and
- (if asked to do so by us) return such Products to our place of business at our cost.

CIRCUMSTANCES WHERE YOUR GUARANTEE DOESN'T APPLY

6. We shall not be liable for the Products' failure to comply with the guarantee set out in paragraph 2 in any of the following events:

- if you make any further use of the Products after giving us notice of an issue in accordance with paragraph 5;
- the defect arises because you failed to follow our oral or written instructions as to the storage, installation [MG5], use and maintenance of the Products;
- the defect arises as a result of your use of the Products with any other software or hardware that is not compatible with the Products;
- the products are used by you for any commercial purpose, including rental or demonstrative purposes;
- you alter or repair the Products without the written consent of HDA;
- the defect arises as a result of an act of god, fair wear and tear, or your misuse, abuse, unreasonable use, wilful damage, negligence, or abnormal storage of the Products or by any other causes unrelated to defective hardware or manufacturing;
- where the serial number has been altered, defaced or removed;
- where the warranty seal on the system has been altered, defaced or removed; or

(i) where the Products differ from their description as a result of changes made to ensure they comply with applicable statutory or regulatory requirements.

TRANSFERRING YOUR GUARANTEE TO SOMEONE ELSE

7. HDA will not accept any liability under such guarantee unless you are the original customer or can produce a letter or chain of letters from the original customer and subsequent customers (where appropriate) transferring the benefit of the guarantee to you.

PRODUCTS THAT ARE NOT COVERED BY THIS GUARANTEE

8. This guarantee does not cover products sold and clearly marked "as is", "B-grade", or with faults. This guarantee does not apply to any system software that is preinstalled in the HDA hardware, or is subsequently provided via update or upgrade releases. Any and all HDA software is licensed to you under the terms of a separate end user licence agreement found here: <https://hdanywhere.com/legals>

HOW THIS GUARANTEE WORKS WITH OUR EULA

9. We may void this guarantee if we reasonably believe that the HDA system has been used in a manner that violates terms of our separate End User Licence Agreement (EULA) for the HDA software. You assume all-risk and liabilities associated with the use of third party products in conjunction with the Products.

YOUR STATUTORY RIGHTS

10. This guarantee is in addition to your statutory rights (including under the Consumer Rights Act) which are not affected by this guarantee

GENERAL TERMS OF THIS GUARANTEE

11. Except as provided in this guarantee, we shall have no liability to you in respect of the Products' failure to comply with the guarantee set out in paragraph 2.

12. We reserve the right to amend or withdraw this guarantee at any time although for the avoidance of doubt any guarantees that are in existence at such a time will be honoured.

13. These Conditions shall apply to any repaired or replacement Product supplied by us.

GUARANTEE CONTACT INFORMATION

To contact (support@hdanywhere.com) or call HDANYWHERE Technical Support (call charges will depend on your telephone provider. Please check with your operator for exact charges).The team is available 9am - 5pm weekdays. To help us handle your query promptly, please have your invoice number and model SKU and serial ready.



Copyright © HDA.

HDA™ is a trading name of HD Connectivity Ltd.

Registered in England & Wales 06046737 VAT 913222367

HDA assumes no responsibility for any inaccuracies that may be contained in this document. In no event will HDA be liable for direct, indirect, special, incidental, or consequential damages resulting from any defect or omission in this document, even if advised of the possibility of such damages.