

HDANYWHERE™



## XTND 2K (60)

CODE: XTND2K60

Product Guide (English UK)

Revision 2: 12/07/21

# Contents

Contents, Glossary of terms	2-3
In the box, Features	4-5
Specifications	6-7
XTND 2K (60) transmitter port description	8-9
XTND 2K (60) receiver port description	10-11
IR (Infrared) control, Testing IR works	12-13
Cabling	14-15
Example wiring diagram, Power up sequence	16-17
2 Year Product Guarantee	18-19
Conformity, Hire a HDA Pro	20

# Glossary of terms

**IR RX & IR TX**

Infrared (IR) Receiver (RX) and Transmitter (TX). The RX 'receives' a signal from another remote control and the TX 'transmits' it. (See page 12)

**EDID**

Extended Display Identification Data (EDID) is a way for display devices to describe their capabilities to a video source. This XTND allows you to choose which display EDID is sent to the connected source.

**XTND transmitter**

Part of the XTND pair. The XTND transmitter takes a HDMI signal and converts it into a format which can be carried over Cat6 cable. The transmitter is installed at the source end of the setup.

**XTND receiver**

Part of the XTND pair. The XTND receiver takes the signal made by the XTND transmitter and converts it back to HDMI so that it can be connected to a display.

# IMPORTANT

For optimum performance and safety, please read these instructions carefully before connecting, operating or configuring this product. Please keep this manual for future reference.

## Surge protection is recommended

This device contains sensitive electrical components that may be damaged by electrical spikes, surges, electric shock, lightning strikes, etc. The usage of surge protection systems is recommended in order to protect and extend the life of your system.

# In the box

Name: **XTND 2K (60)**  
Product code: **XTND2K60**

**x1** XTND 2K (60) Transmitter

**x1** XTND 2K (60) Receiver

**x1** Infrared Transmitter cable (1.5m) (IR TX)

**x1** Infrared (20-60Khz) Receiver cable (1.5m) (IR RX)

**x1** 12V 1A Power Supply with adapters (UK,EU,US,AU)

**x1** User Manual

# Features

Maximum video picture format up to 4K@30Hz (4:4:4)\*

1080p up to 60m (197ft)

Local HDMI loop out

Power from XTND transmitter

Digital audio support up to and including Dolby Atmos and DTS:X

IR passback from receiver to transmitter

**\*4K transmission using HDMI 1.4 + HDCP 1.4 only.**

# Specifications

HDMI version	HDMI 1.4
HDCP compliance	HDCP 1.4
Video bandwidth	10.2Gbps
Video resolution	Up to 4K@30Hz (4:4:4)*
Colour space	RGB, YCbCr 4:4:4, YUV 4:4:4, YCbCr 4:2:2/4:2:0
Colour depth	8-bit, 10-bit, 12-bit (1080p@60Hz)
Video & audio I/O	<b>Input:</b> x1 HDMI <b>Outputs:</b> x1 HDMI, x1 HDMI (Mirror)
Transmission distance	1080p 60m (197ft) 4K 40m (131ft)
HDMI audio formats	PCM 2.0 / 5.1 / 7.1, Dolby Digital / Plus / EX / True HD / Atmos, DTS, DTS-EX, DTS-96 / 24, DTS High Res, DTS-HD Master Audio, DTS-X
Infrared	20Khz - 60Khz
ESD protection	±8kV (Air-gap discharge) ±4kV (Contact discharge)



Power consumption	2.73W (Maximum)
Power supply	12V 1A
Operating temperature	0°C - 40°C / 32°F - 104°F
Storage temperature	-20°C - 60°C / -4°F - 140°F
Relative humidity	20 - 90% (Non-condensing)
Housing	Aluminium
Colour	Grey (Carbonite)
Dimensions (W/D/H) mm	Transmitter: 79.5 x 69 x 16.5 Receiver: 79.5 x 69 x 16.5
Weight	Transmitter: 112g Receiver: 112g
Package weight	530g

**\*4K transmission using HDMI 1.4 + HDCP 1.4 only.**

# Transmitter Diagram





# Description

1. **HDMI (IN)**: HDMI video input.

2. **HDMI (OUT)**: HDMI video output.

3. **DC12V**: Connect the supplied power supply to this port to provide power to the XTND system.

4. **IR (OUT)**: Connect an IR TX to the "IR OUT" to enable remote (IR) control of any AV device local to the XTND transmitter.

5. **EDID**: Set EDID from the display connected to the XTND Transmitter (TX) or Receiver (RX).

6. **VIDEO**: Video output port (RJ45). The port has two indicator lights. Left light: solid means the XTND has power and is on. Right light: solid means that the XTND transmitter is connected to an active HDMI source.

# Receiver Diagram



# Description

1. **HDMI (OUT):** HDMI video output. Connect to your display to provide a picture.

2. **IR (IN):** Connect an IR RX to the "IR IN" port to receive an IR command from a remote control to pass through to the XTND transmitter.

3. **VIDEO:** Video output port (RJ45). The port has two indicator lights. Left light: solid means the XTND has power and is on. Right light: solid means that the XTND transmitter is connected to the XTND transmitter and that a HDMI signal is being detected.

# IR (Infrared) control

XTND can send IR signals from the XTND receiver back to the XTND transmitter to control almost any AV device located near it.

## Sending IR commands from a display 'back' to the XTND transmitter

1. Connect an IR TX to port labelled "IR (OUT)" on the XTND transmitter.

2. Place the IR TX bud (small tear drop part) in front of the IR window of the device that you wish to control.

3. Connect an IR RX to port labelled "IR (IN)" on the XTND receiver.

4. Place IR RX in line-of-sight of the remote control.

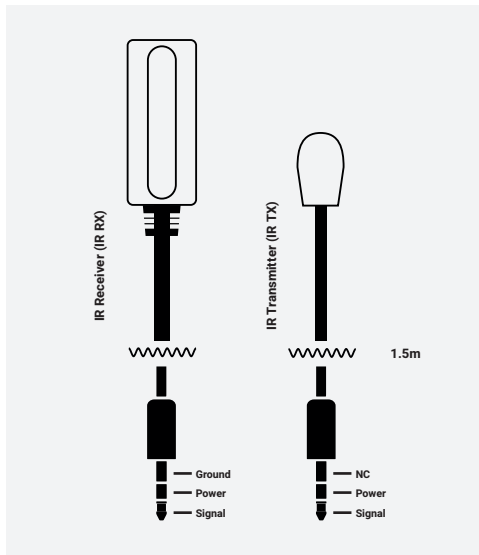

# Testing that IR works

This section aims to verify that your XTND's IR control system is setup correctly and assumes that all other setup has been followed as per the instructions laid out in this manual. Please refer to the XTND wiring diagrams in this document to ensure that your setup matches that before proceeding with the verification below.

## **Testing operation from a display 'back' to the XTND transmitter**

Start this test by ensuring that your XTND system is powered on and your source device (connected to your XTND transmitter) is being correctly displayed on screen. Check that your IR cabling is correctly connected to your XTND system (page 12) and that your remote control has a clear line-of-sight to the IR RX. Point your remote at the IR RX and test a remote control command for your source device. You should notice that it responds as if the source device was directly in front of you. If it worked then you have setup IR control correctly.

# Cabling

Currently you can use Cat6, Cat6e, Cat6a, Cat7 or Cat7a with XTND. Cat5e may work, but is not recommended, due to its limited bandwidth capabilities.

## Optimum performance

Whichever network cable type you choose, ensure that the main wiring architecture is 'solid core' and not stranded 'patch' cabling. Patch cabling can be used for the last few metres of a run (e.g wallplate) but should be avoided over longer runs as signal transfer over stranded cores is significantly impacted. The use of pre-made leads is not recommended unless you can be absolutely sure of their construction credentials (i.e. solid core 568B). For optimum performance, use a single piece of Cat cable terminated directly at the transmitter and the receiver ends. Make sure to use the correct connector types (i.e. RJ45 solid core) crimp connectors.

## Shielded cables

Shielded FTP cable is not a stipulation. However, if you are using this type of cable ensure compatible shielded accessories are used. Failure to terminate cable screen at all points can induce interference rather than eliminate it.

## Patch panels and wall plates

If patch panels are terminated correctly then there is a minimal loss of distance. The use of wallplates and patch panels has the potential to cause increased resistance on the cable introducing pinch points for signal transmission and could reduce transmission lengths. TIP: Instead of using RJ45 wallplates use brush plates.



## HDMI cabling

HDANYWHERE recommends using suitably robust and good quality HDMI cables. It is not advised to use passive HDMI cables over 5 metres in length either on the inputs or the outputs of the XTND system. Where HDMI cables longer than 5 metres are required, HDA recommends utilising its own brand of long distance HDMI cables or a suitable alternative.

**Note:**

DO NOT USE ANY COPPER CLAD ALUMINIUM (CCA) Cat 6/7 CABLE.

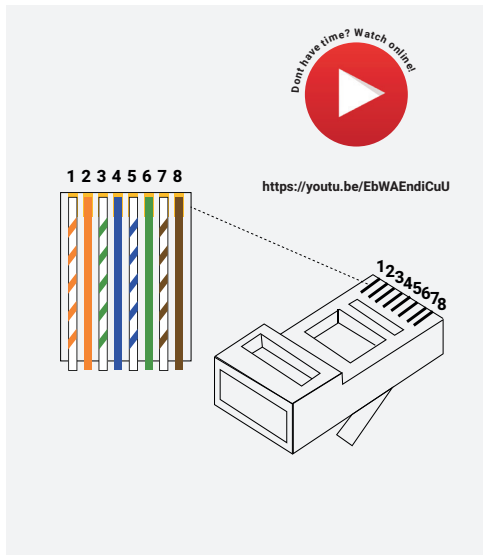

Terminate using RJ45 connectors to 568B wiring standard.

# Example wiring diagram

We have detailed a setup to show how the main feature-set of this XTND system could be used and demonstrated together.

In this diagram, an Apple TV is being extended to a display with an additional mirrored output supplied to a local TV nearby. The Apple TV is controlled by sending commands from its native remote control at the XTND receiver end through the system and reproduced at the transmitter location providing distance remote control.

## Note:

This XTND system has been designed so that it can be installed in multiple ways. The purpose of the diagram is to illustrate a typical/example setup and assumes that you are already familiar with the basics of wiring and infrastructure. If you are unsure how you might install this device in to your property then contact support@hdanywhere.com or contact a HDA Pro (<https://hdanywhere.com/dealers-and-installers/>) for further assistance.

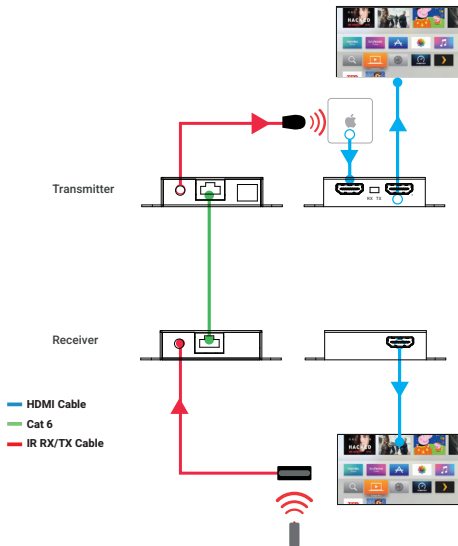



# Power up sequence

- 1 Ensure that all devices are turned off.
- 2 Connect HDMI source to "HDMI (IN)" port on the XTND transmitter.
- 3 Connect the XTND transmitter and receiver together by using Cat 6/7 cable connected to the each end of the "Video" port.
- 4 Connect a display to the "HDMI (OUT)" port on the XTND receiver.
- 5 If any devices require IR control, ensure that IR is connected at this stage as well (page 12).
- 6 Plug in the supplied power lead in the XTND transmitter. XTND will automatically power on. XTND power indicator LEDs should be lit and solid.
- 7 Turn on the source device followed by the display.
- 8 Ensure that your display is set to the correct AV channel.
- 9 A picture should now be displayed.

# 2 Year Guarantee

## WHO WE ARE

1. We are HD CONNECTIVITY LTD trading as HDANYWHERE ("HDA"), a limited company registered under number 06046737 in England and Wales with its registered offices at The Haysfield, Malvern, WR14 1GF, United Kingdom.

## OUR GUARANTEE TO YOU

2. We, HDANYWHERE warrant to you, the end user of the HDA hardware (the "Products") that on the date of delivery of the Products to you, and for a period of 2 years from that date of delivery, the Products shall:

- match any description that has been provided to you;
- be free from any significant defects in their design, the materials used to make them, and the way they are made;
- be of satisfactory quality (within the meaning of the Consumer Rights Act 2015); and
- be fit for any purpose held out by us.

This 2 year period, or, if the period has been extended to 3 years in accordance with paragraph 3, will be the "Guarantee Period". We offer this guarantee to all our customers who are resident and have an address in Great Britain and Northern Ireland.

## EXTENDING YOUR GUARANTEE (NOT APPLICABLE TO ANY XTND)

3. On registering your Products with the HDA Cloud, the guarantee offered in paragraph 2 by us will automatically extend for a period of one year, provided that your registration takes place within 30 days from the date of delivery. The one year guarantee extension starts automatically from the date that the original 2 year guarantee ends.

## HOW TO CLAIM ON YOUR GUARANTEE AND YOUR REMEDIES

4. Subject to paragraphs 5 and 6 of this guarantee, Your sole remedies under Our guarantee to You are as follows:

- Up to 30 days: we will repair or replace your Products or provide you with a full refund of the price of the defective Products at your option.
- Up to 6 Months: we will repair or replace your Products. If we are unable to repair or replace your Products we will provide you with a full refund of the price of the defective Products.
- Up to 2 (3) Years: we will repair or replace your Products. If we are unable to repair or replace your Products we will provide you with a partial refund of the price of the defective Products based upon the devaluation of the Products since the time of purchase.

5. In order to claim under the guarantee given to you in paragraph 2 you will need to:

- give us notice in writing of your intention to claim under the guarantee during the Guarantee Period, and do so within a reasonable time after finding that some or all of the Products do not comply with the guarantee set out in paragraph 2;
- show that the Products that you claim are defective, have been examined by a HDA Pro or other authorised or suitably qualified installer, and that they have [MG3] confirmed in writing that the suspected defect in the Products stems solely from a fault in the HDA hardware;
- give us a reasonable opportunity to examine the Products in question;
- provide us with an order number and a dated sales or delivery receipt from an HDA Distributor, HDA Pro or other authorised dealer, reseller or installer of the Products.
- obtain from us in advance of returning the Products a return merchandise authorisation and/or case number [MG4]; and
- (if asked to do so by us) return such Products to our place of business at our cost.

## CIRCUMSTANCES WHERE YOUR GUARANTEE DOESN'T APPLY

6. We shall not be liable for the Products' failure to comply with the guarantee set out in paragraph 2 in any of the following events:



Help is only an email away: [support@hdanywhere.com](mailto:support@hdanywhere.com).

- (a) If you make any further use of the Products after giving us notice of an issue in accordance with paragraph 5;
- (b) the defect arises because you failed to follow our oral or written instructions as to the storage, installation[MG5], use and maintenance of the Products;
- (c) the defect arises as a result of your use of the Products with any other software or hardware that is not compatible with the Products;
- (d) the products are used by you for any commercial purpose, including rental or demonstrative purposes;
- (e) you alter or repair the Products without the written consent of HDA;
- (f) the defect arises as a result of an act of god, fair wear and tear, or your misuse, abuse, unreasonable use, wilful damage, negligence, or abnormal storage of the Products or by any other causes unrelated to defective hardware or manufacturing;
- (g) where the serial number has been altered, defaced or removed;
- (h) where the warranty seal on the system has been altered, defaced or removed; or
- (i) where the Products differ from their description as a result of changes made to ensure they comply with applicable statutory or regulatory requirements.

**TRANSFERRING YOUR GUARANTEE TO SOMEONE ELSE**

7. HDA will not accept any liability under such guarantee unless you are the original customer or can produce a letter or chain of letters from the original customer and subsequent customers (where appropriate) transferring the benefit of the guarantee to you.

**PRODUCTS THAT ARE NOT COVERED BY THIS GUARANTEE**

8. This guarantee does not cover products sold and clearly marked "as is", "B-grade", or with faults. This guarantee does not apply to any system software that is preinstalled in the HDA hardware, or is subsequently provided via update or upgrade releases. Any and all HDA software is licensed to you under the terms of a separate end user licence agreement found here: <https://hdanywhere.com/legals>

**HOW THIS GUARANTEE WORKS WITH OUR EULA**

9. We may void this guarantee if we reasonably believe that the HDA system has been used in a manner that violates terms of our separate End User Licence Agreement (EULA) for the HDA software. You assume all-risk and liabilities associated with the use of third party products in conjunction with the Products.

**YOUR STATUTORY RIGHTS**

10. This guarantee is in addition to your statutory rights (including under the Consumer Rights Act) which are not affected by this guarantee

**GENERAL TERMS OF THIS GUARANTEE**

- 11. Except as provided in this guarantee, we shall have no liability to you in respect of the Products' failure to comply with the guarantee set out in paragraph 2.
- 12. We reserve the right to amend or withdraw this guarantee at any time although for the avoidance of doubt any guarantees that are in existence at such a time will be honoured.
- 13. These Conditions shall apply to any repaired or replacement Product supplied by us.

**GUARANTEE CONTACT INFORMATION**

To contact ([support@hdanywhere.com](mailto:support@hdanywhere.com)) or call HDANYWHERE Technical Support (call charges will depend on your telephone provider. Please check with your operator for exact charges).The team is available 9am - 5pm weekdays. To help us handle your query promptly, please have your invoice number and model SKU and serial ready.

# Important information

## **EU Conformity**

Hereby, HDANYWHERE declares that this HDMI connectivity device is in compliance with the essential requirements and other relevant provisions of the following Directives: 2006/95/EC (LVD Directive); 2004/108/EC (EMC Directive); 1999/5/EC (R&TTE Directive). The full text of the EU declaration of conformity is available in the compliance section at [HDANYWHERE.com/legals](https://hdanywhere.com/legals)

## **Recycling your device properly**

In some areas, the disposal of certain electronic devices is regulated. Make sure you dispose of or recycle your device in accordance with your local laws and regulations.



# Hire a HDA Pro

If cabling infrastructure, installation and control seem like too much to absorb and learn then why not hire a HDA Pro to do the work instead for you? Having your XTND system professionally installed should help to guarantee the system's long-term performance and ensure that it blends neatly with your decor.

**Find a HDA Pro anywhere in the world today <https://hdanywhere.com/dealers-and-installers/>**



HDANYWHERE

**Let us know what you think.**

We would love to hear how we could further improve our products and services.  
If we can make something better, please let us know!

[support@hdanywhere.com](mailto:support@hdanywhere.com)

Copyright © HDANYWHERE.

HDANYWHERE™ is a trading name of HD Connectivity Ltd.

Registered in England & Wales 06046737 VAT 913222367

HDANYWHERE assumes no responsibility for any inaccuracies that may be contained in this document. In no event will HDANYWHERE be liable for direct, indirect, special, incidental, or consequential damages resulting from any defect or omission in this document, even if advised of the possibility of such damages.